



## Request for Quote/Proposal (RFQ/RFP)

Commodity/Service Required:	Next Generation Mobile Energy System
Type of Procurement:	One-Off Purchase Agreement
Type of Contract:	Purchase Order
Term of Contract:	6 months
Contract Funding:	U.S. Department of State (DOS)
This Procurement supports:	Energy Secure Philippines Activity (ESP)
Submit Proposal to:	<b>Ms. Divina B. Chingcuanco</b> Chief of Party, ESP RTI International via email: <a href="mailto:jvitan@energysecure.ph">jvitan@energysecure.ph</a>
Date of Issue of RFP:	May 8, 2026
Date Questions from Supplier Due:	<b>June 30, 2026 - 5:00PM Philippine Standard Time</b> ; June 5, 2026
Date Proposal Due:	<b>Reopened until July 7, 2026 - 5:00PM Philippine Standard Time</b> ; June 22, 2026
Approximate Date Purchase Order Issued to Successful Bidder(s):	On or before July 30, 2026
<b>Method of Submittal:</b>	
Email to <a href="mailto:jvitan@energysecure.ph">jvitan@energysecure.ph</a>	
Respond via e-mail with attached document in MS Word / pdf format. The Bidder/Seller agrees to hold the prices in its offer firm for <b>60 days</b> from the date specified for the receipt of offers, unless another time is specified in the addendum of the RFP/RFQ.	
Solicitation Number:	ESP-PR-2026-011

### Attachments to RFP:

1. Attachment "A" – Commodity Specifications
2. Attachment "B" – Instructions to Bidders/Sellers
3. Attachment "C" – List of Geocode 937 compliant countries
4. All PO Terms and Conditions are listed on our website at: [RTI-PO-Terms English Version - v1.21.pdf](#) or for commercial items: [http://www.rti.org/files/PO FAR Clauses Commercial Items.pdf](http://www.rti.org/files/PO_FAR_Clauses_Commercial_Items.pdf) (hereinafter the "Terms"). Supplier's delivery of products, performance of services, or issuance of invoices in connection with this purchase order establishes Supplier's agreement to the Terms. The Terms may only

**RTI International is a trade name of Research Triangle Institute. RTI and the RTI logo are U.S. registered trademarks of Research Triangle Institute.**



3040 Cornwallis Road ■ PO Box 12194 ■ Research Triangle Park, NC 27709-2194 ■ USA  
Telephone 919.541.6000 ■ Fax 919.541.5985 ■ [www.rti.org](http://www.rti.org)

be modified in writing signed by both parties.

All bidders/sellers are responsible to carefully review each attachment and follow any instructions that may be relevant to this procurement.

**RTI International is a trade name of Research Triangle Institute. RTI and the RTI logo are U.S. registered trademarks of Research Triangle Institute.**

# Attachment A

## Commodity Specifications

### Statement of Work

#### Description of Activity/Service:

RTI International (RTI) is a global, independent research institute with almost 60 years of experience in creating and translating knowledge into practice. RTI has expertise in at least 250-degree fields working to unlock value in eight practice areas including health, education, energy, environmental sciences, and innovation ecosystems.

RTI is currently implementing Energy Secure Philippines (ESP), which is a multi-year program that aims to assist the Government of the Philippines (GPH) in promoting a more competitive power sector through investment mobilization, deployment of modern energy technologies, and support in policy reforms and regulation. ESP's overall goal is to enhance energy security and reliability in the Philippines. It focuses on advancing inclusive economic growth and resilient development through increased private investment, promoting advanced technology deployment, and boosting the energy sector's resiliency.

On January 20, 2025, the US Government issued Executive Order 14169 designed to revisit and realign the country's foreign assistance. Viewed through this lens, the America First policy frames U.S aid primarily as a tool to advance direct American interests and emphasizes strict alignment of assistance with U.S. national security, economic, and strategic priorities; a preference for measurable returns that make America safer, stronger, or more prosperous. Under this approach, foreign assistance is scrutinized for cost-effectiveness and political alignment, often favoring trade, investment, private-sector solutions, and cost-sharing, while reducing or restructuring programs seen as inefficient, dependency creating, or insufficiently tied to U.S. interests.

In partnership with the Philippine Department of Energy, ESP successfully implemented a program that strengthened the energy sector's capacity to prepare for, respond to, and recover from disasters through capacity-building initiatives and innovative, sustainable energy solutions. A key innovation under the program is the Mobile Energy System (MES), a mobile, energy-resilient platform capable of operating independently of the main grid to ensure the continuity of essential services during emergencies. Each MES unit is housed in a refurbished 20-foot container mounted on a trailer truck and equipped with high-efficiency solar panels and battery storage of up to 51.2 kWh, enabling up to 12 hours of power for critical appliances, lighting, and communications equipment. The MES supports disaster response operations, temporary rescue stations, and the continued operation of critical facilities, particularly in underserved and off-grid communities.

ESP plans to deploy the next-generation MES units designed to:

- Integrate advanced and innovative technologies that improve reliability, efficiency, safety,

and operational flexibility compared to existing MES models.

- Enhance resilience against natural disasters, cyber threats, and power system disruptions.
- Support rapid deployment and ease of transport, including operation in remote and off-grid areas.
- Utilize clean and sustainable energy sources, with provisions for hybridization (e.g., solar, battery storage, and backup generation);
- Incorporate smart energy management systems, including real-time monitoring, remote diagnostics, and cybersecurity features.

Product or Service Expectations (both if applicable):

The detailed specification of this RFQ is in **Annex 1**

Deliverables, Timelines, Special Terms and Conditions:

- The proposal to be submitted should all be Geocode 937 compliant (**Attachment C**). However, the bidder may propose alternative sources and/or brands for consideration.
- The bidders should indicate the delivery date for each item and/or lead time
- The price must exclude the VAT and indicate that component in separate line item.
- Delivery address will be determined later but within Philippine.

Proposal should consist of documents as follows:

- Proof of legal registration
- List of previous clients that are relevant to RTI business
- Signed RFQ document (page 5)

***ESP reserves the right to award to several bidders and fund any or none of the applications submitted, subject to the availability of funds.***

## Pricing



3040 Cornwallis Road ■ PO Box 12194 ■ Research Triangle Park, NC 27709-2194 ■ USA  
Telephone 919.541.6000 ■ Fax 919.541.5985 ■ www.rti.org

Item #	Quantity to be Purchased	Description of Preferred Commodity or Services Specifications	Unit of Measure	Unit Fixed Price (Each)	Total Fixed Price (Each)	Lead Time Availability (Number of Days)
1						
2						
3						
<b>Total Value</b>						

By signing this attachment, the bidder confirms he has a complete understanding of the specifications and fully intends to deliver items that comply with the above listed specifications.

Signature:

Title:

Date:

## **Attachment “C”**

### **List of Geocode 937 compliant countries**

## List of Developing Countries

### A Mandatory Reference for ADS Chapter 310

New Edition: 02/06/2012  
Responsible Office: GC  
File Name: 310maa\_020612

02/06/2012New Edition

Low income/lower middle income

Afghanistan	Gambia, The	Myanmar
Bangladesh	Guinea	Nepal
Benin	Guinea-Bissau	Niger
Burkina Faso	Haiti	Rwanda
Burundi	Kenya	Sierra Leone
Cambodia	Korea, Dem Rep.	Somalia
Central African Republic	Kyrgyz Republic	Tajikistan
Chad	Liberia	Tanzania
Comoros	Madagascar	Togo
Congo, Dem. Rep	Malawi	Uganda
Eritrea	Mali	Zimbabwe
Ethiopia	Mozambique	
Angola	India	São Tomé and Príncipe
Armenia	Iraq	Senegal
Belize	Kiribati	Solomon Islands
Bhutan	Kosovo	Sri Lanka
Bolivia	Lao PDR	Sudan
Cameroon	Lesotho	Swaziland
Cape Verde	Marshall Islands	Syrian Arab Republic
Congo, Rep.	Mauritania	Timor-Leste
Côte d'Ivoire	Micronesia, Fed. Sts.	Tonga
Djibouti	Moldova	Turkmenistan
Egypt, Arab Rep.	Mongolia	Tuvalu
El Salvador	Morocco	Ukraine
Fiji	Nicaragua	Uzbekistan
Georgia	Nigeria	Vanuatu
Ghana	Pakistan	Vietnam
Guatemala	Papua New Guinea	West Bank and Gaza
Guyana	Paraguay	Yemen, Rep.
Honduras	Philippines	Zambia
Indonesia	Samoa	

310maa\_020612

## Attachment “B” Instructions to Bidders/Sellers

- Procurement Narrative Description:** The Buyer (RTI) intends to purchase commodities and/or services identified in Attachment A. The Buyer intends to purchase the quantities (for commodities) and/or services (based on deliverables identified in a Statement of Work). The term of the Ordering Agreement shall be from Award Date to the Delivery date of the Offeror unless extended by mutual agreement of the parties. The Buyer intends to award to a single “approved” supplier based on conformance to the listed specifications, the ability to service this contract, and selling price. We reserve the right to award to more than one bidder. If an Ordering Agreement is established as a result of this RFQ/RFP, supplier understands that quantities indicated in the specifications (Attachment A) are an estimate only and RTI does not guarantee the purchase quantity of any item listed.
- Procuring Activity:** This procurement will be made by **Research Triangle Institute (RTI International)**, located at

Manila, Philippines.

*(insert full address of the office)*

who has a purchase requirement in support of a project funded by

U.S. Department of State

*(insert client’s name)*

RTI shall award the initial quantities and/or services and any option quantities (if exercised by RTI) to Seller by a properly executed Purchase Order as set forth within the terms of this properly executed agreement. RTI is seeking quotations for equipment/services to deploy the next-generation MES units using two (2) designs presented in Annex 1 pages 14-17 of this document.

- Proposal Requirements.** All Sellers will submit a quote/proposal which contains offers for all items and options included in this RFQ/RFP. All information presented in the Sellers quote/proposal will be considered during RTI’s evaluation. Failure to submit the information required in this RFQ/RFP may result in Seller’s offer being deemed non-responsive. Sellers are responsible for submitting offers, and any modifications, revisions, or withdrawals, so as to reach RTI’s office designated in the RFQ/RFP by the time and date specified in the RFQ/RFP. Any offer, modification, revision, or withdrawal of an offer received at the RTI office designated in the RFQ/RFP after the exact time specified for receipt of offers is “late” and may not be considered at the discretion of the RTI Procurement Officer. The Seller’s proposal shall include the following:
  - The solicitation number:
  - The date and time submitted:
  - The name, address, and telephone number of the seller (bidder) and authorized signature of same:
  - Validity period of Quote:

- (e) A technical description of the items being offered in sufficient detail to evaluate compliance with the requirements in the solicitation. This may include product literature, or other documents, if necessary.
  - (f) If RTI informs Seller that the Commodity is intended for export and the Commodity is not classified for export under Export Classification Control Number (ECCN) “EAR99” of the U.S. Department of Commerce Export Administration Regulations (EAR), then Seller must provide RTI the correct ECCN and the name of Seller’s representative responsible for Trade Compliance who can confirm the export classification.
  - (g) Lead Time Availability of the Commodity/Service.
  - (h) Terms of warranty describing what and how the warranties will be serviced.
  - (i) Special pricing instructions: Price and any discount terms or special requirements or terms (special note: pricing must include guaranteed firm fixed prices for items requested.)
  - (j) Payment address or instructions (if different from mailing address)
  - (k) Acknowledgment of solicitation amendments (if any)
  - (l) Past performance information, when included as an evaluation factor, to include recent and relevant contracts for the same or similar items and other references (including points of contact with telephone numbers, and other relevant information)
  - (m) **Special Note:** *The Seller, by his response to this RFQ/RFP and accompanying signatures, confirms that the terms and conditions associated with this RFQ/RFP document have been agreed to and all of its attachments have been carefully read and understood and all related questions answered.*
4. **Forms:** Sellers (potential bidders or suppliers) must record their pricing utilizing the format found on Attachment “A”. Sellers must sign the single hardcopy submitted and send to address listed on the cover page of this RFQ/RFP.
5. **Questions Concerning the Procurement.** All questions in regards to this RFQ/RFP to be directed to

Jan Ranizen Vitan, Procurement and Contracts Manager

(insert name of procurement officer)

at this email address:

[jvitan@energysecure.ph](mailto:jvitan@energysecure.ph)

(insert email address of the procurement officer).

The cut-off date for questions is (insert date).

June 30, 2026

6. **Notifications and Deliveries:** Time is of the essence for this procurement. Seller shall deliver

the items or services no later than the dates set forth in the contract that will be agreed by both parties as a result of this RFQ/RFP. The Seller shall immediately contact the Buyer's Procurement Officer if the specifications, availability, or the delivery schedule(s) changes. Exceptional delays will result in financial penalties being imposed of Seller.

7. **Documentation:** The following documents will be required for payment for each item:
  - (a) A detailed invoice listing Purchase Order Number, Bank information with wiring instructions (when applicable)
  - (b) Packing List
  - (c) All relevant product/service documentation (manuals, warranty doc, certificate of analysis, etc.)
8. **Payment Terms:** Refer to RTI purchase order terms and conditions found in [https://www.rti.org/sites/default/files/rti-po-terms\\_v1.21.pdf](https://www.rti.org/sites/default/files/rti-po-terms_v1.21.pdf), [http://www.rti.org/files/PO\\_FAR\\_Clauses.pdf](http://www.rti.org/files/PO_FAR_Clauses.pdf), or [http://www.rti.org/files/PO\\_FAR\\_Clauses Commercial Items.pdf](http://www.rti.org/files/PO_FAR_Clauses_Commercial_Items.pdf). Payment can be made via wire transfer or other acceptable form. Sellers may propose alternative payment terms and they will be considered in the evaluation process.
9. **Alternative Proposals:** Sellers are permitted to offer "alternatives" should they not be able to meet the listed requirements. Any alternative proposals shall still satisfy the minimum requirements set forth in Attachment A Specifications.
10. **Inspection Process:** Each item shall be inspected prior to final acceptance of the item. All significant discrepancies, shortages, and/or faults must be satisfactorily corrected and satisfactorily documented prior to delivery and release of payment.
11. **Evaluation and Award Process:** The RTI Procurement Officer will award an agreement contract resulting from this solicitation to the responsible Seller (bidder) whose offer conforms to the RFQ/RFP will be most advantageous to RTI, price and other factors considered. The award will be made to the Seller representing the **best value** to the project and to RTI. For the purpose of this RFQ/RFP, price, delivery, technical and past performance are of equal importance for the purposes of evaluating, and selecting the "best value" awardee. RTI intends to evaluate offers and award an Agreement without discussions with Sellers. Therefore, the Seller's initial offer should contain the Seller's best terms from a price and technical standpoint. However, RTI reserves the right to conduct discussions if later determined by the RTI Procurement Officer to be necessary.

The evaluation factors will be comprised of the following criteria:

- (a) **PRICE.** Lowest evaluated ceiling price (inclusive of option quantities).
- (b) **DELIVERY.** Seller provides the most advantageous delivery schedule.
- (c) **TECHNICAL.** Items/Services shall satisfy or exceed the specifications described in RFQ/RFP Attachment A.
- (d) **PAST PERFORMANCE** - Seller can demonstrate his/her capability and resources to provide the items/services requested in this solicitation in a timely and responsive manner.
- (e) **OTHER EVALUATION CRITERIA.**

None
------



12. **Award Notice.** A written notice of award or acceptance of an offer, mailed or otherwise furnished to the successful supplier within the time acceptance specified in the offer, shall result in a binding contract without further action by either party.
13. **Validity of Offer.** This RFP in no way obligates RTI to make an award, nor does it commit RTI to pay any costs incurred by the Seller in the preparation and submission of a proposal or amendments to a proposal. Your proposal shall be considered valid for 60 days after submission.
14. **Representations and Certifications.** Winning suppliers under a US Federal Contract are required to complete and sign as part of your offer RTI Representations and Certifications for values over \$10,000.
15. **Certification.** The offeror, by signing its offer, hereby certifies to the best of its knowledge and belief that no Federal appropriated funds have been paid or will be paid to any person for influencing or attempting to influence an officer or employee of any agency, a Member of Congress, an officer or employee of Congress, or an employee of a Member of Congress on its behalf in connection with the awarding of this contract.
16. **Anti- Kick Back Act of 1986.** Anti-Kickback Act of 1986 as referenced in FAR 52.203-7 is hereby incorporated into this Request for Proposal as a condition of acceptance. If you have reasonable grounds to believe that a violation, as described in Paragraph (b) of FAR 52.203-7 may have occurred, you should report this suspected violation to the RTI's Ethics Hotline at 1-877-212-7220 or by sending an e-mail to [ethics@rti.org](mailto:ethics@rti.org). You may report a suspected violation anonymously.
17. **The John S. McCain National Defense Authorization Act for fiscal year 2019 - section 889.** RTI cannot use any equipment or services from specific companies, or their subsidiaries and affiliates, including Huawei Technologies Company, ZTE Corporation, Hytera Communications Corporation, Hangzhou Hikvision Digital Technology Company, and Dahua Technology Company ("Covered Technology"). In response to this request for proposal, please do not provide a quote which includes any Covered Technology. Any quote which includes Covered Technology will be deemed non-responsive. Additionally, if the United States Government is the source of funds for this RFP, the resulting Supplier shall not provide any equipment, system, or service that uses Covered Technology as a substantial or essential component

**Acceptance:**

Seller agrees, as evidenced by signature below, that the seller's completed and signed solicitation, seller's proposal including all required submissions and the negotiated terms contained herein, constitute the entire agreement for the services described herein.

By: *(Seller Company Name)*

Signature: \_\_\_\_\_

Title:

Date:

**Annex 1. Detail Specification and Quotation template**

<b>No. of Units</b>	<b>Description</b>
2	100 kWh for 50 kVA
4	50 kWh for 35 kVA
4	50 kWh for 20 kVA
10	Charging station for a battery swapping energy management system

**QUOTATION FORM**

<b>Item</b>	<b>Particulars</b>	<b>Unit</b>	<b>Unit Cost</b>	<b>Amount</b>	<b>Remarks</b>
<b>1</b>	<b><i>General Requirements</i></b>				
	1.01 Mobilization (freight & handling)	lot			
	1.02 Engineering Drawings and Documents	lot			
	a. As-Plan and As-Built Drawings: Detailed electrical plans and schematic diagram, signed and approved				
	b. Compilation of Test Reports, Warranty Certificates, Product Brochures				
	c. Operations and Maintenance Manual				
<b>2</b>	<b><i>Supply of the MES</i></b>				
	2.01 540 Wp Solar Panels				
	2.01 PV mounting structure, steel frames, and accessories (railings, clamps, etc.)  <i>Important to observe structural integrity to ensure it can withstand strong winds (e.g., typhoons).</i>	lot			
	2.03 Battery storage with MPPT charge controller. Total capacity: 50kWh, Type: LiFePO4 batteries, 48V, 200Ah				
	2.04 Inverter, Single Phase, Hybrid On-Grid/ Off-Grid				
	2.05 Battery Management System (BMS)				
	2.06 Deployable panel board, circuit breakers, switches, conduit, cables and accessories for the MES container	lot			

Item	Particulars	Unit	Unit Cost	Amount	Remarks
<b>3</b>	<b><i>Mobile container with trailer bed (chassis &amp; wheels) and Charging Station Structure</i></b>				
	3.01 Supply of mobile container with trailer bed (chassis & wheels)  Inclusions: <i>itemize according to the design</i>	lot			
<b>4</b>	<b><i>Installation, Testing and Commissioning</i></b>				
	4.01 Installation, testing and commissioning of solar panels, inverter, battery storage, BMS, and protective devices.	lot			
	4.02 Supply and installation of load-side inlet and Emergency Panel Board at deployment site -at least 100-meter royal cord cable	lot			
<b>5</b>	<b><i>Training and After-sales Support</i></b>				
	5.01 Conduct training of the beneficiaries Operations and Maintenance Team.	lot			
	5.02 After-sales Support Team shall stay on-site after deployment date to ensure the smooth operation of the MES.				
	5.03 24/7 after-sales support through SMS, call, or online.				
<b>6</b>	<b><i>OTHERS</i></b>				
	Contractors list all needed items which are not reflected in the BOM but deemed necessary for the project accomplishment.	lot			

**SUB-TOTAL**

-

**TOTAL COST ESTIMATE**

-

**Design #1: Mini Trailer with Charging Station (battery swapping energy management system)**

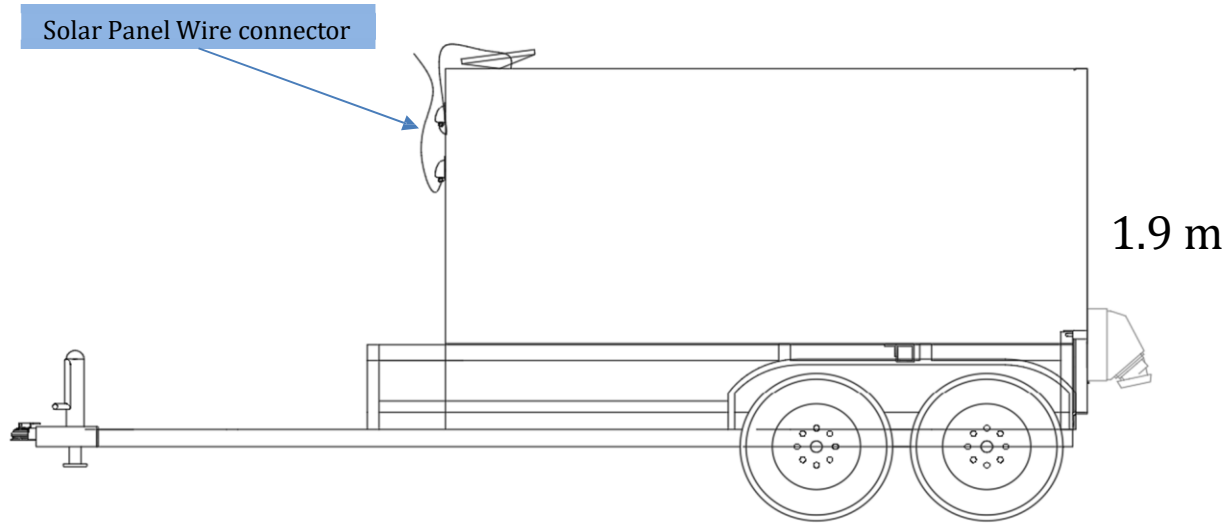

~ 4.4 meters  
**SIDE VIEW**

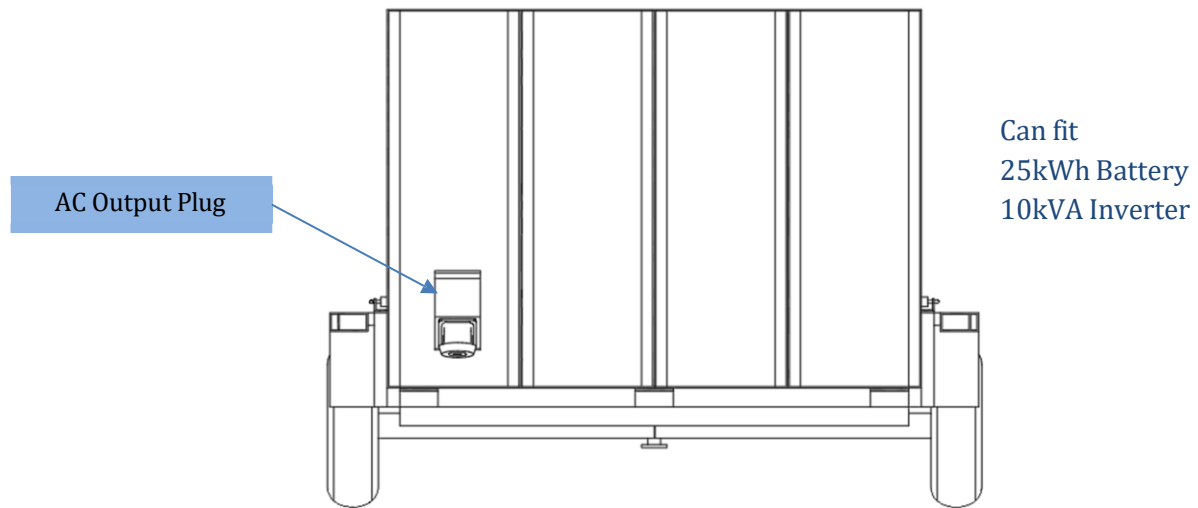

~ 2.4 meters  
**REAR VIEW**

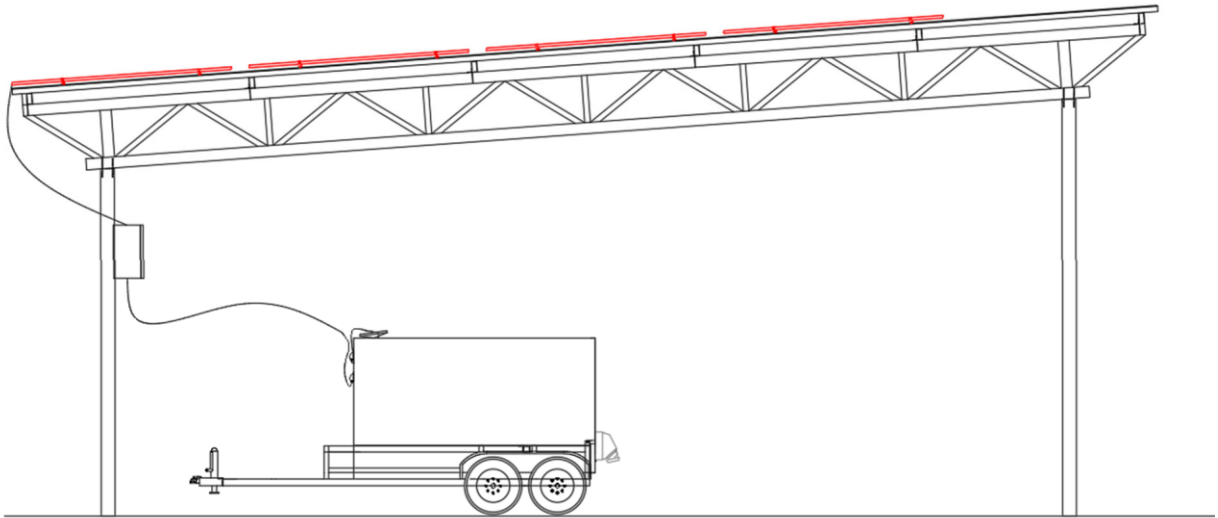

**SOLAR CHARGING STATION SIDE VIEW**

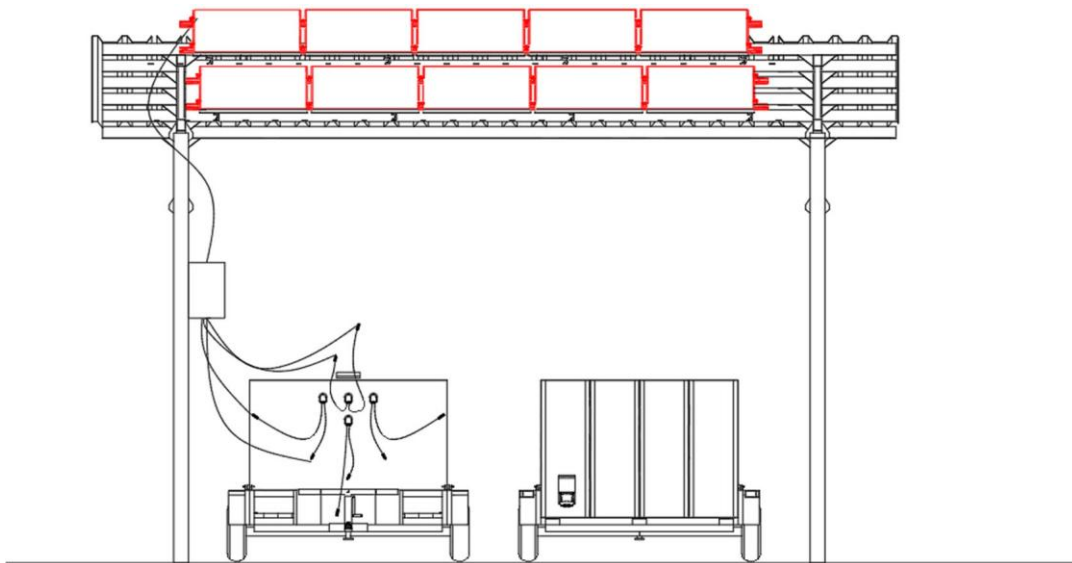

**SOLAR CHARGING STATION REAR VIEW**

**Design #2: Easy Rolling MES with Charging Station (battery swapping energy management system)**

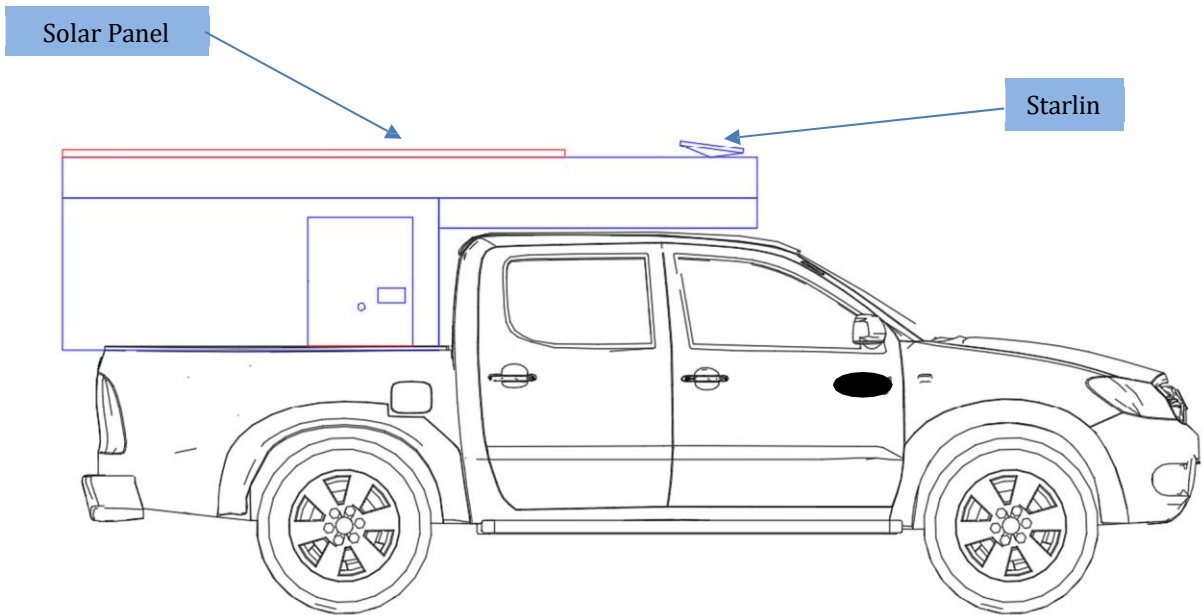
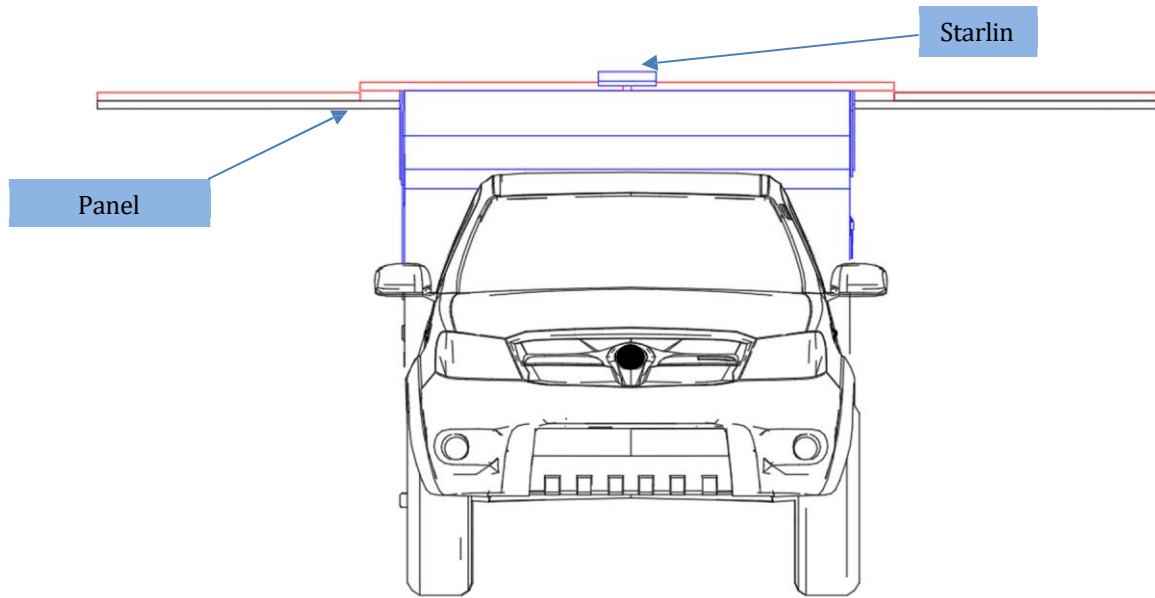

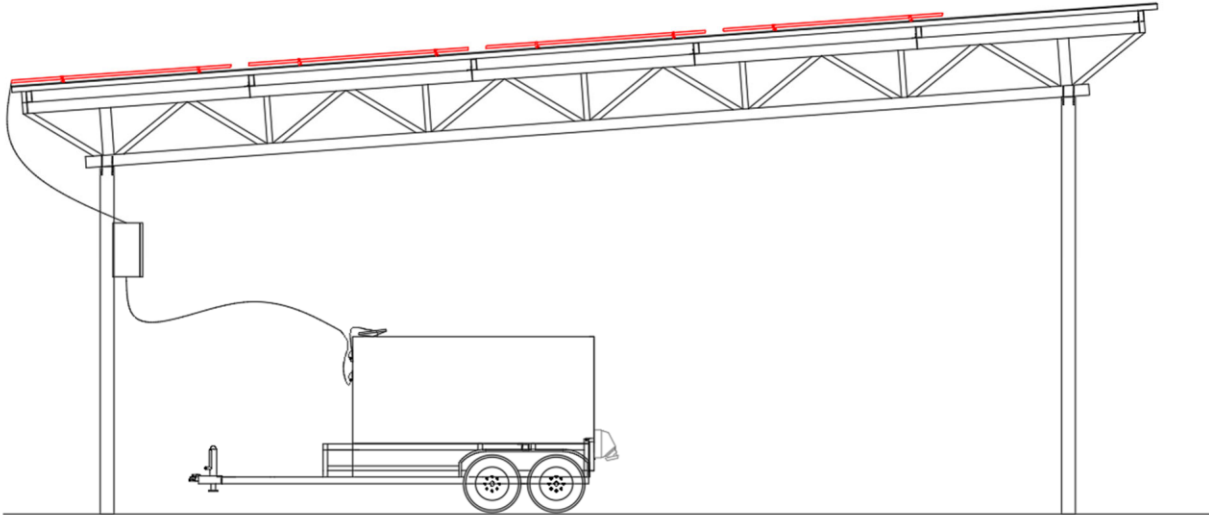

**SOLAR CHARGING STATION SIDE VIEW**

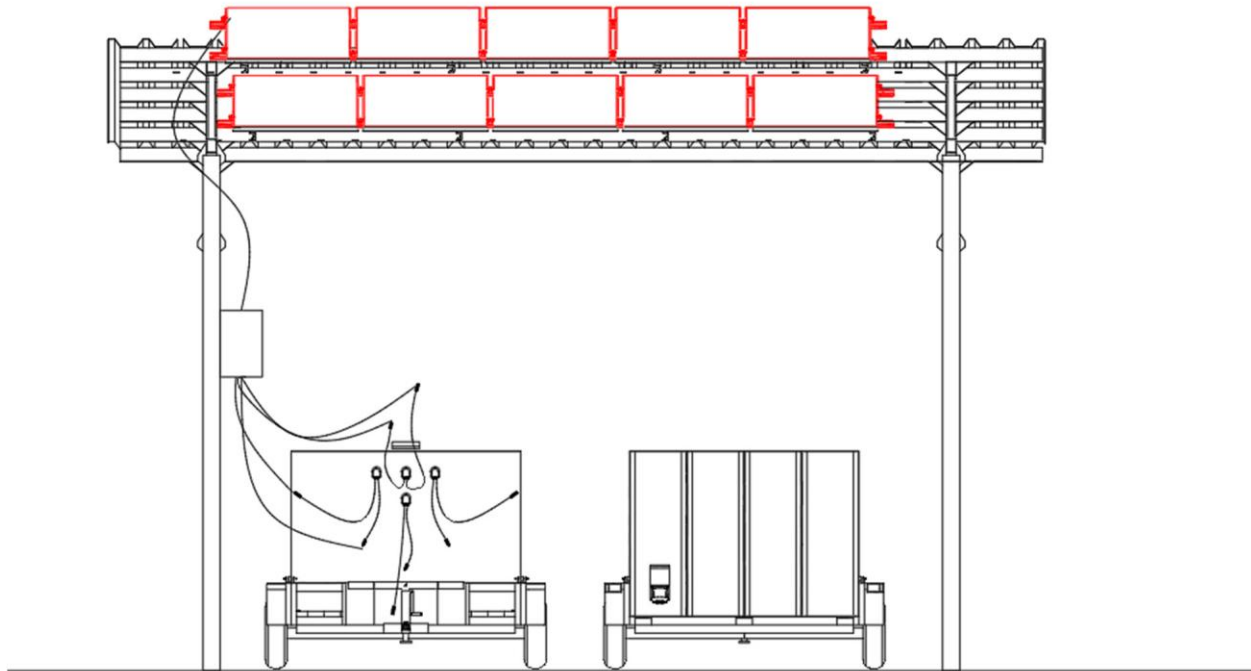

**SOLAR CHARGING STATION REAR VIEW**